

EXERFIT 110 bench

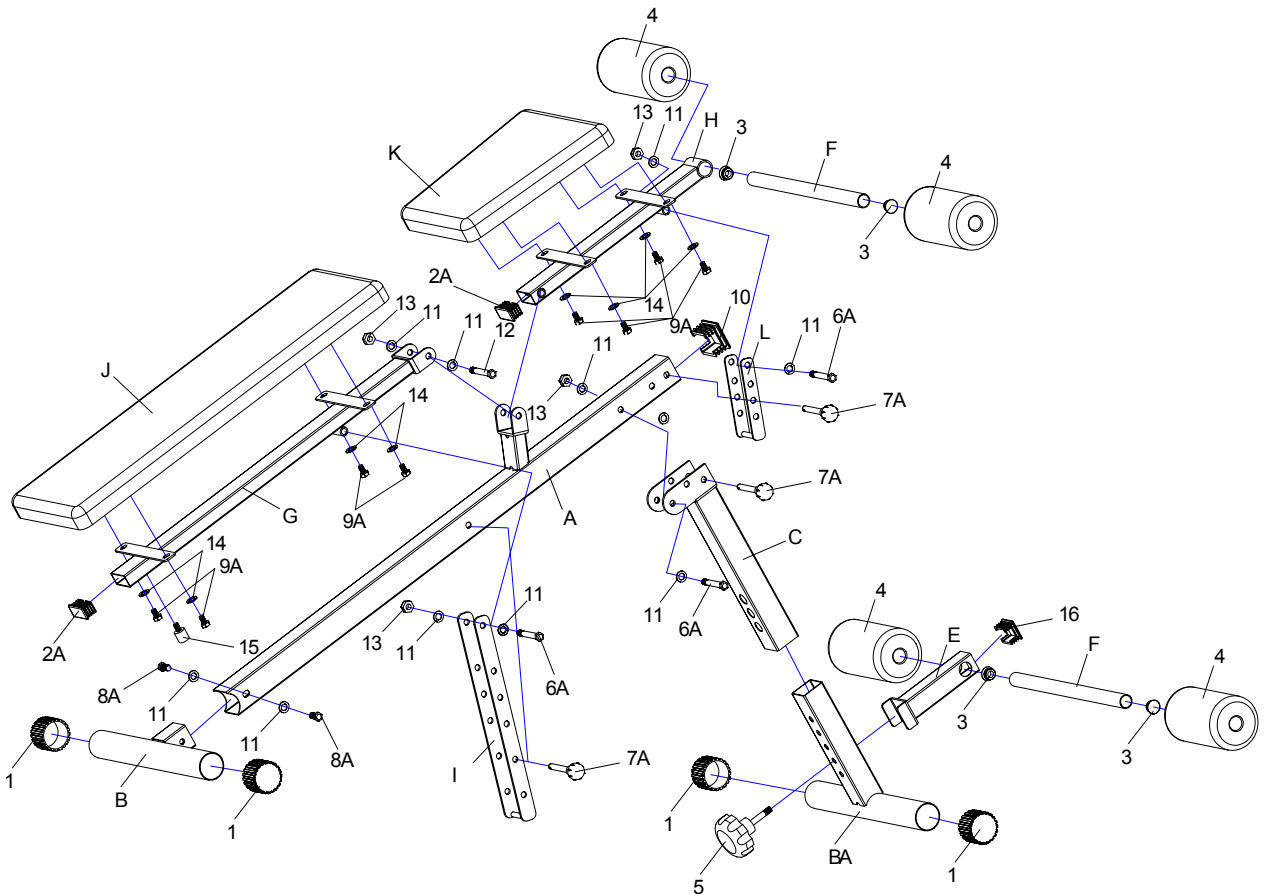
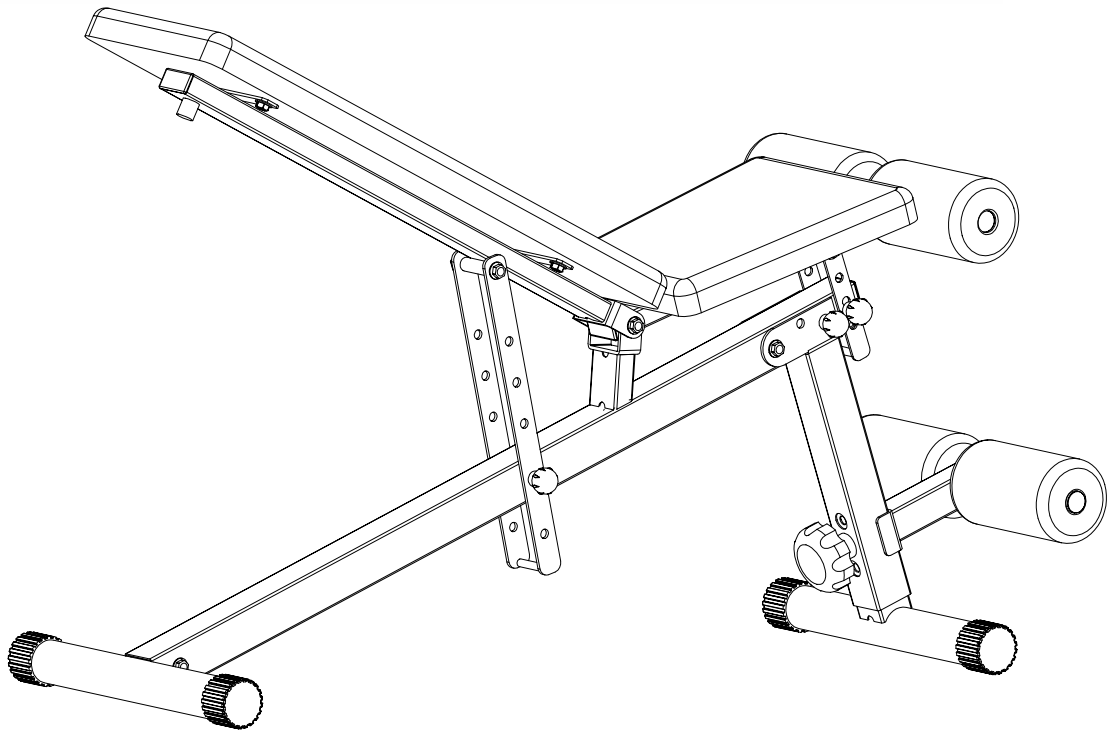

Part List

Item no.	Description	Q'ty
1	ENDEKAPEL.50	4
2A.	PULGG50*25	2
3	AKSEL PULGG.25	4
4.	SKUMRULL	4
5.	SKRUE,JUST	1
6A.	BOLT M10*75	3
7A.	PIN	3
8A.	BOLT M10*20	2
9A.	BOLT M8*15	8
10.	PULGG50	1
11.	WASHER M10	10
12.	BOLT M10*85	1
13.	NYLON LOCK NUT M10	4
14.	WASHER M8	8
15	RUBBER BUMPER	1
16	PULG 38	1
A.	HOVEDRAMME	1
B.	STABILISTOR	1
BA.	FROND STABILISTOR	1
C.	RAMME	1
E.	RAMME, SKUMRULL	1
F.	AKSEL,SKUMRULL	2
G.	RAMME,RYGGSTQTTE	1
H.	RAMME JUSTERBAR	1
I.	RAMME JUSTERBAR	1
J.	PUTE RYGGSTQTTE	1
K.	PUTE SETE	1
L.	SEAT RAMME JUSTERBAR	1